

## 1. Introduction

This technical note is intended to provide information about the proper power-on procedure of the Kionix **KXG03** accelerometer/gyroscope sensor.

Proper functioning of power-on reset (POR) is dependent on the specific **VDD**, **VDD<sub>LOW</sub>**, **T<sub>VDD</sub>** (rise time), and **T<sub>VDD\_OFF</sub>** profile of individual applications. It is recommended to minimize **VDD<sub>LOW</sub>**, and **T<sub>VDD</sub>**, and maximize **T<sub>VDD\_OFF</sub>**. It is also advised that the VDD ramp up time **T<sub>VDD</sub>** be monotonic. To assure proper POR in all environmental conditions the application should be evaluated over the customer specified range of **VDD**, **VDD<sub>LOW</sub>**, **T<sub>VDD</sub>**, **T<sub>VDD\_OFF</sub>** and temperature as POR performance can vary depending on these parameters

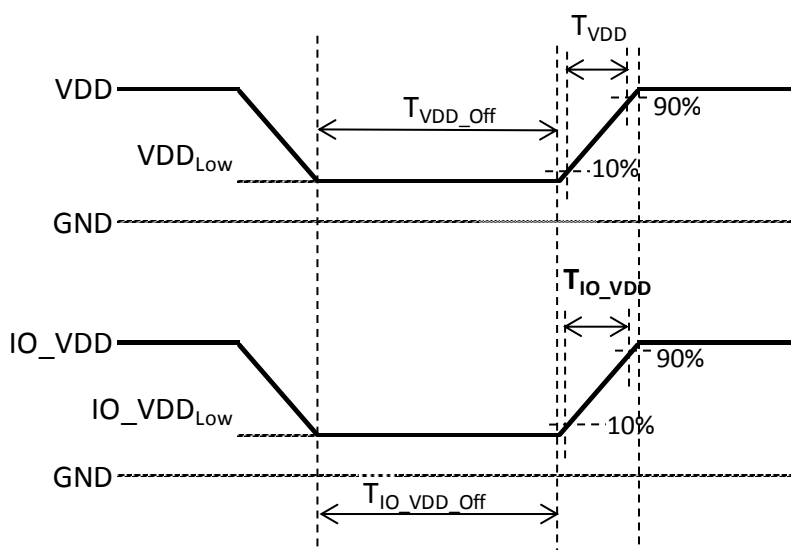

**Figure 1: Power-On Reset Timing Diagram**

**2. POR Performance**

Bench Testing has demonstrated POR performance regions for a proper POR trigger. To assure POR trigger properly executes, setting operational thresholds consistent with Table 1 is recommended.

Parameters	Units	Min	Typical	Max
VDD rise time: $T_{VDD}^{1,2,3}$	ms			5
IO_VDD rise time: $T_{IO\_VDD}^{1,2,3}$	ms			5
VDD off time: $T_{VDD\_OFF}^{4,6}$	ms	20		
IO_VDD off time: $T_{IO\_VDD\_OFF}^{4,6}$	ms	20		
VDD low voltage: $VDD_{Low}^{4,6}$	mV			200
IO_VDD low voltage: $IO\_VDD_{Low}^{4,6}$	mV			200
Software Reset Time <sup>6</sup>	ms			2
Power Up Time <sup>7</sup>	ms			50

**Table 1: POR Performance**

Notes:

1. VDD and IO\_VDD must always be monotonic ramps without ambiguous state
2.  $T_{VDD}$  and  $T_{IO\_VDD}$  rise from 10% to 90% of final value needs to be  $\leq 5$ ms.
3. IO\_VDD amplitude must remain  $\leq VDD$ .
4.  $T_{VDD\_OFF}$  and  $T_{IO\_VDD\_OFF}$  are off time for VDD and IO\_VDD rails respectively. In order to prevent the sensor from entering an ambiguous state, both VDD and IO\_VDD need to be pulled down to GND ( $\leq 200$ mV) for duration of time  $\geq 20$  ms.
5. It is important the user determines the timing ( $T_{VDD\_OFF}$ ) and threshold ( $VDD_{Low}$ ) levels by evaluating the performance in the specific system for which the device will be incorporated.
6. Software Reset Time is defined as time it takes to perform a RAM reboot routine following the setting of SRST bit to 1 in the CTL\_REG\_1. The SRST bit will remain 1 until the RAM reboot routine is completed.
7. Power Up Time is defined as time from VDD and IO\_VDD become valid to device boot completion.

**3. Software Reset**

Issuing the Software Reset command after the device was powered up is recommended. This is effective against dynamic or non-linear behavior of a power supply or unexpected noise above normal on the power rail during a power up.

**3.1. I<sup>2</sup>C Interface**

**3.1.1. I<sup>2</sup>C Slave Addresses for Software Reset**

The Software Reset command may need to be sent to **two** I<sup>2</sup>C slave addresses. The 7-bit slave address associated with KXG03 is 10011YX, where the user programmable bit X, is determined by the assignment of ADDR pin 7 to GND or IO\_VDD. The factory programmable bit Y is set at the factory. An unsuccessful power-on may cause the internal value of the programmable bit Y to be flipped from 0 to 1 or 1 to 0. As a result, the user will need to take this into account and possibly send the required commands to the ‘flipped’ I<sup>2</sup>C address if attempts to send to the ‘primary’ address have failed. The Table 2 shows the ‘primary’ and ‘flipped’ 7-bit slave addresses for devices with ADDR pin connected to IO\_VDD.

Description	Address Pad	7-bit Address	<7>	<6>	<5>	<4>	<3>	Y	X
								<2>	<1>
I <sup>2</sup> C Primary Address	IO_VDD	0x4F	1	0	0	1	1	1	1
I <sup>2</sup> C Flipped Address		0x4D	1	0	0	1	1	0	1

**Table 2:** I<sup>2</sup>C Primary and Flipped 7-bit Slave Addresses with ADDR pin (X) at IO\_VDD

The Table 3 shows the ‘primary’ and ‘flipped’ 7-bit slave addresses for devices with ADDR pin connected to GND.

Description	Address Pad	7-bit Address	<7>	<6>	<5>	<4>	<3>	Y	X
								<2>	<1>
I <sup>2</sup> C Primary Address	GND	0x4E	1	0	0	1	1	1	0
I <sup>2</sup> C Flipped Address		0x4C	1	0	0	1	1	0	0

**Table 3:** I<sup>2</sup>C Primary and Flipped 7-bit Slave Addresses with ADDR pin (X) at GND

### 3.1.2. Software Reset Sequence following Power Up

- a. Following the power up, write 0x00 to internal register 0x2F using I<sup>2</sup>C Primary Address as specified in Table 2 or Table 3 depending of the connection of ADDR pin. If command was acknowledged (ACK received), proceed to the next step while addressing the device using I<sup>2</sup>C Primary Address. If ACK was not received, resend the command using I<sup>2</sup>C Flipped Address. If command was acknowledged, proceed to the next step while addressing the device using I<sup>2</sup>C Flipped Address. If command was not acknowledged again, the device should be power cycled.

Register Name	Address	Value
0x2F	0x2F	0x00

- b. Write 0x00 to Control Register 1 (CTL\_REG\_1). If NACK received, the device should be power cycled.

Register Name	Address	Value
CTL_REG_1	0x44	0x00

- c. Write 0x80 to Control Register 1 (CTL\_REG\_1) to initiate software reset, which performs the RAM reboot routine. If software reset command was acknowledged (ACK received), wait for the duration of time specified in Table 1 for completion of the Software Reset and proceed to the next step. If NACK received, the device should be power cycled.

Register Name	Address	Value
CTL_REG_1	0x44	0x80

- d. Read content of “Who am I” register (WHO\_AM\_I) using the I2C Primary Address. The expected value is shown below. If value read is not what is expected, the software reset has failed and the device should be power cycled.

Part	Register Name	Address	Value
KXG03-1034	WHO_AM_I	0x30	0x24

**Table 4:** Expected Values of Who\_Am\_I register for KXG03

### 3.1.3. Software Reset Timing Diagram

Figure 2 below shows an example of executing Software Reset sequence outlined section 3.1.2 following a power up. The first attempt is to communicate with device using I<sup>2</sup>C Primary Address as specified in Table 2 or Table 3 depending of the connection of ADDR pin. If attempt is unsuccessful, the second attempt is to communicate with device using I<sup>2</sup>C Flipped Address mentioned in the same tables. Please wait for the duration of time specified in Table 1 for completion of the Software Reset before proceeding.

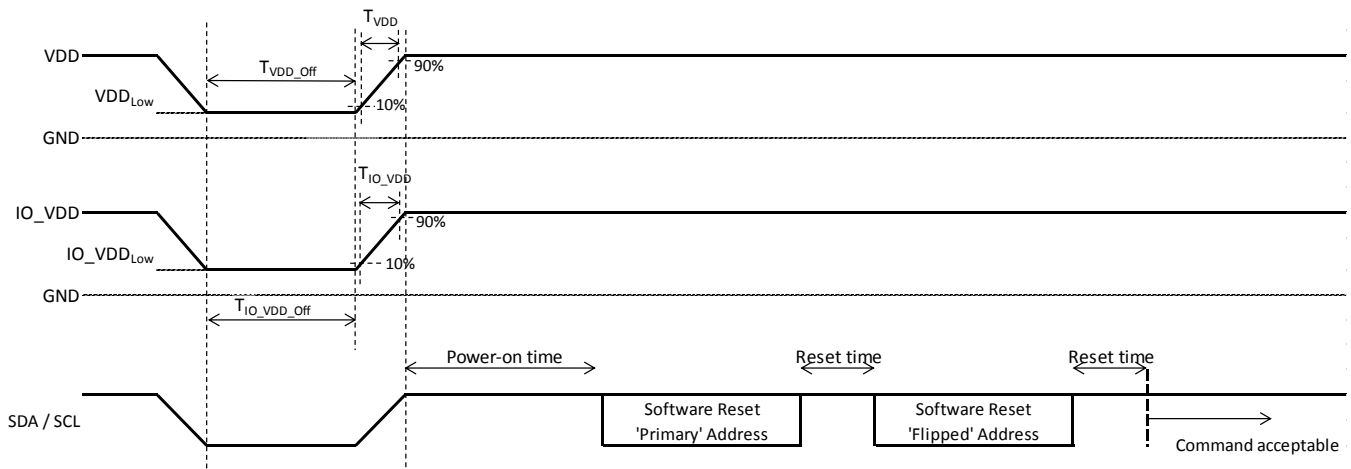

**Figure 2:** Power-On Timing Diagram followed by sending of two I<sup>2</sup>C Software Reset Commands

3.2. SPI Interface

3.2.1. Software Reset Sequence following Power Up

- a. Following the power up, write 0x00 to internal register 0x2F

Register Name	Address	Value
0x2F	0x2F	0x00

- b. Write 0x00 to Control Register 1 (CTL\_REG\_1). If NACK received, the device should be power cycled.

Register Name	Address	Value
CTL_REG_1	0x44	0x00

- c. Write 0x80 to Control Register 1 (CTL\_REG\_1) to initiate software reset, which performs the RAM reboot routine. If software reset command was acknowledged (ACK received), wait for the duration of time specified in Table 1 for completion of the Software Reset and proceed to the next step. If NACK received, the device should be power cycled.

Register Name	Address	Value
CTL_REG_1	0x44	0x80

- d. Read content of “Who am I” register (WHO\_AM\_I) using the *PC Primary Address*. The expected value of the sensor is shown below. If value read is what is not what is expected, the software reset has failed and the device should be power cycled.

Part	Register Name	Address	Value
KXG03-1034	WHO_AM_I	0x30	0x24

**Table 5:** Expected Values of Who\_Am\_I register for KXG03/KXG07/KXG08

### 3.2.2. Software Reset Timing Diagram

Figure 3 below shows an example of sending Software Reset following the initial power on. Please wait for the duration of time specified in Table 1 for completion of the Software Reset before proceeding.

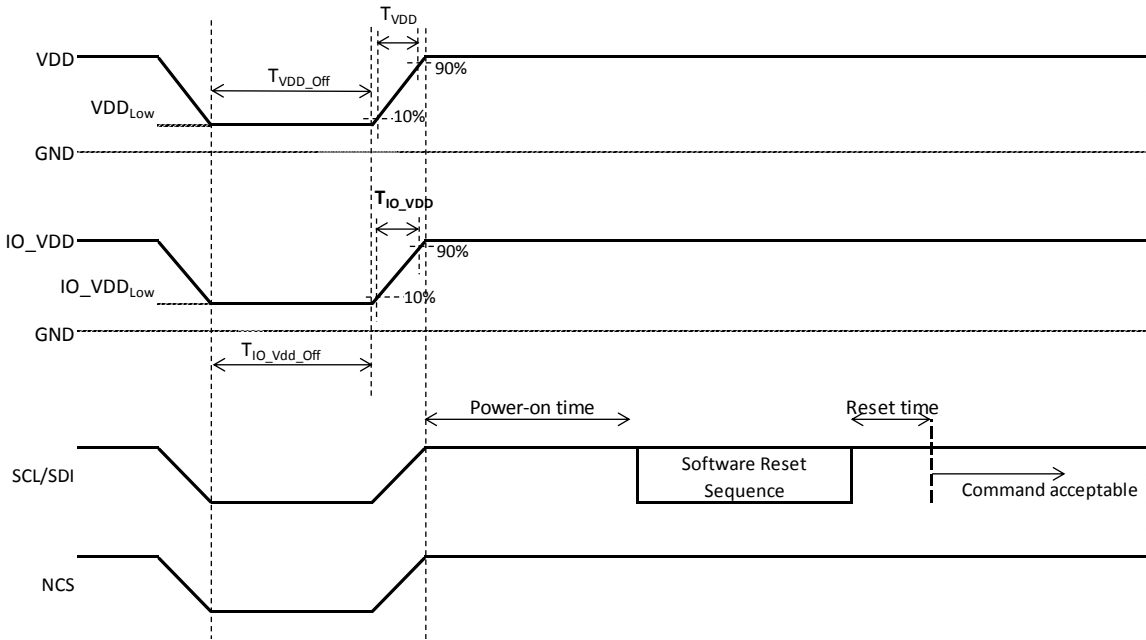

Figure 3: Power-On Timing Diagram followed by sending Software Reset Commands

The data provided by Kionix is intended for initial customer design guidance only. Kionix POR testing looks at a finite number of test configurations. Each customer application will have varying input sensor parameters (electrical, mechanical, and environmental) that will be different than the configurations tested by Kionix. Each customer utilizing the sensor will need to properly validate the sensor (including POR function) within their application under their specific use cases to ensure it responds as required.